

Professional warewashing technology

m
MEIKO

The clean solution

Quality and convenience at a fair price

With
the MEIKO
"GiO MODULE"
water treatment
technology:
No need to polish
glasses ever
again!

UPster® U / UPster® H

Professional warewashing technology
for new entrants and upgraders



www.meiko.info

UPster®

More quality, higher performance,
more machine for less money



MEIKO: the art of making good things even better. For this reason we have redesigned all machines in the successful MEIKO *UPster*® series. The results are in a class of their own. Perfect for getting started or switching to the professional warewashing technology from MEIKO. With the completely fair price/

performance ratio only offered by *UPster*®. Whether undercounter or hood type dishwashing machines – the new *UPster*® series scores with robust materials, improved technology and more intuitive operation. For longer machine service life, more comfort and greater savings in water, energy and working hours.



The clean solution



The new MEIKO *UPster*® range of machines makes light work of washing up, and it makes it easier for you to take the plunge into professional warewashing technology!



UPster® U series

under the counter but exceeding the standard



MEIKO's new *UPster*® U range of undercounter dishwashers pulls out all the stops when it comes to professional warewashing technology, offering efficient cleaning performance, easy operation, maximum flexibility, and exceptional value for money. The perfect choice for your wash-up area. Simply plug it in and you're ready to go!



UPster® U 400

Get glassware and washware sparkling clean in no time!

Easy and convenient to operate with an intuitive control panel and digital display. Double-walled thermal insulation to keep the heat in and minimise energy use. That's a pretty cool package!



UPster® U 400

Entry height

H 300 mm

Dimensions

H 700-730 mm,
W 460 mm, D 600 mm

Rack dimensions

400 x 400 mm

Capacity

up to 30 racks/h

UPster® U 400

All the plus points at a glance

The UPster® U 400 in figures

- **Suitable for tall glasses:** Entry height 300 mm
- **Small but fine:** rack size 400 x 400 mm
- **Miserly consumption:** 2.2 l per wash cycle

Safety and hygiene

- **Reliable hygiene with no compromises** thanks to digital temperature display for wash and final rinse temperatures
- **Excellent washing results** thanks to excellent leachate filtration and optimum tank water regeneration with the eco-filter system
- **Cleanliness down to the smallest nooks & crannies** due to top and bottom washing and rinsing system

Comfort and serviceability

- **Uncomplicated operation thanks to the fully electronic control** with 3 program cycle times
- **Operating errors excluded** thanks to the highly intuitive operating concept
- **Always a clean wash chamber** due to convenient self-cleaning program
- **Protects glasses and dishes** with a wash pump with soft start

Quality and longevity

- **Remains quiet and cool outside** by double-walled construction with insulation of the door
- **Robust and hygienic** thanks to extended wash chamber with integrated rack guides
- **Protection of the machine components** by stainless steel back wall panelling

Simple installation and service

- **Simple ordering, fast delivery**
- **Immediately installed:** complete connection kit for water, waste water and electricity included
- **Plugs in anywhere:** 400 V or 230 V – can be changed on site
- **Easy maintenance:** electronic interface and easy service access

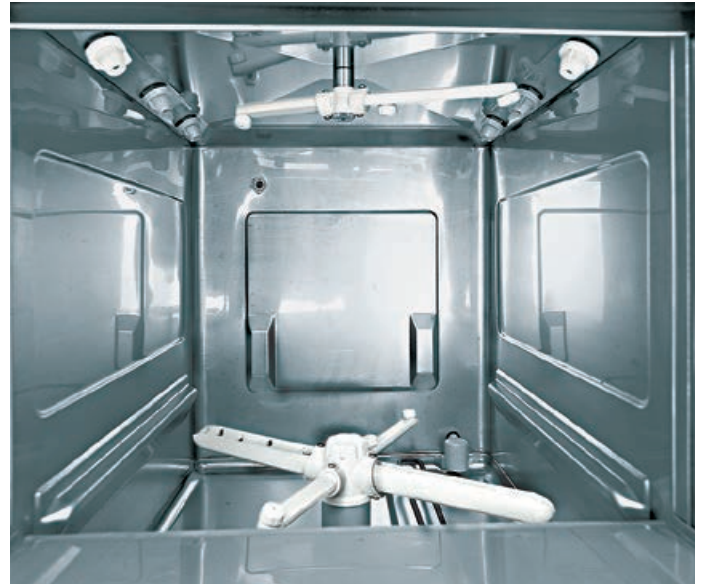

The stripped down pro wash chamber: robust technology and premium materials ensure long machine service life and easy cleaning.

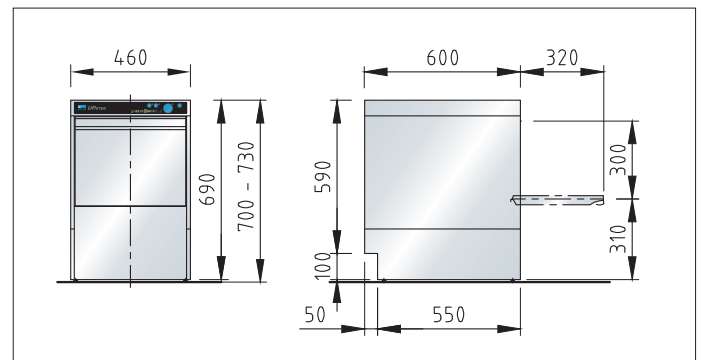

UPster® U 500 / U 500 G

The economic miracle under the counter

The new *UPster® U 500 G* glasswasher effortlessly cleans cups, plates and cutlery. It is a robust "all-rounder" for the counter area. Everything that has to be clean and spotless at the counter fits in here.

Thank to the top wash system no corner remains dry. The simple operation and the many comfort features ensure a hygienic and convincing wash result. With its lower overall height, the *UPster® U 500 G* fits under nearly every counter. Whether mounted on a plinth or with integrated *GiO MODULE* under the machine.

The new *UPster® U 500* is a solid all-rounder: tableware and glasses as well as larger items of washware are handled with ease. With its appealing, modern design and the use of proven MEIKO technology, the *UPster® U 500* always cuts a fine figure even behind the counter. And the features speak for themselves: spacious wash compartment, comfortable self-cleaning program, soft start for very gentle washing, 3 program cycle times, convincing consumption values and *GiO MODULE* (optional). And all for an absolutely fair price. The makes the *UPster® U 500* into the cleaning star in the new price/performance class from MEIKO.



UPster® U 500 G

Optional extras:

- MEIKO *GiO MODULE* technology
- **under the machine**
(Fig. with GiO-MODULE under the machine)
H 820-850 mm
- **on the rear panel of the machine**
D 690 mm
- **adjacent to the machine or in another room e.g.**
W 140 mm, D 550 mm, H 600 mm

Entry height

H 315 mm

Dimensions

H 700-730 mm, W 600 mm,
D 600 mm

Rack dimensions

500 x 500 mm

Capacity

up to 40 racks/h



UPster® U 500

Optional extras:

- MEIKO *GiO MODULE* technology
- **under the machine**
H 940-970 mm
- **on the rear panel of the machine**
(Fig. with GiO-MODULE on the rear panel of the machine)
D 690 mm
- **adjacent to the machine or in another room e.g.**
W 140 mm, D 550 mm, H 600 mm

Entry height

H 420 mm

Dimensions

H 820-850 mm, W 600 mm,
D 600 mm

Rack dimensions

500 x 500 mm

Capacity

up to 40 racks/h

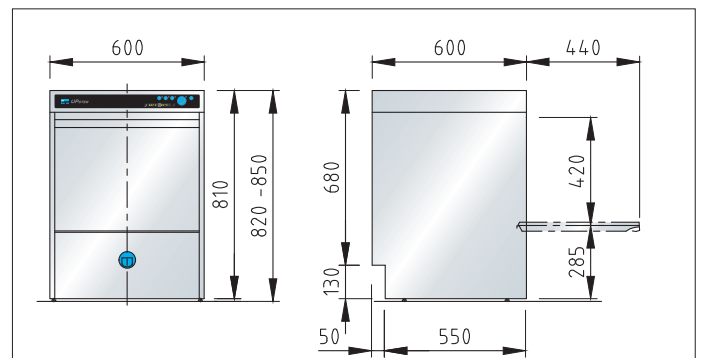
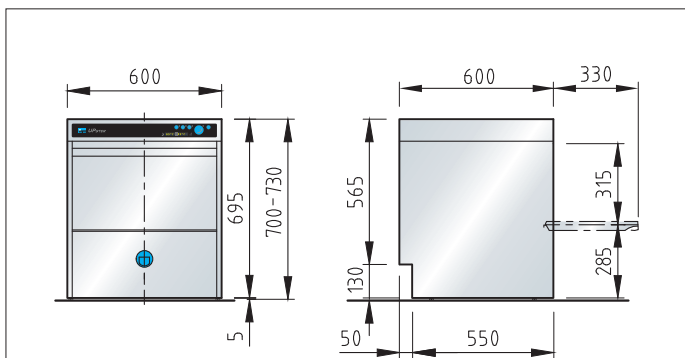

UPster® U 500 / U 500 G

All the plus points at a glance

The UPster® U 500 / U 500 G in figures

- **Outstanding for large plates, cups and cutlery:**
Entry height 315 mm (U 500 G), 420 mm (U 500)
- **A lot of space for brilliant wash results:**
rack size 500 x 500 mm
- **Efficient water consumption:** 2.6 l per wash cycle

Hygiene assurance and cleanliness

- **Hygiene assurance without compromises** thanks to digital temperature display for wash and final rinse temperatures, and permanent temperature control
- **Excellent rinsing results** due to excellent wash water filtration and optimum tank water regeneration with the *AktivPlus* wash water filter system
- **Cleanliness that penetrates the last nook and cranny** with the top and bottom wash and final rinse system
- **No detergent residues:** Due to the inbuilt gradient in the wash and final rinse systems as well as the washing compartment ceiling, no drops fall on the cleaned washware
- **Consistent, reliable cleaning results:** Thanks to the pressure booster pump cleans the *UPster® U 500 G/ U 500* independently of the mains water pressure

Comfort and serviceability

- **Uncomplicated operation thanks to the fully electronic control** with 3 program cycle times
- Highly intuitive blue operating concept **eliminates risk of operator errors**
- **Always a clean wash chamber** through the intuitive self-cleaning program and tank cover sieve for selective removal of dirt in the *AktivPlus* fine filter
- **Protects glasses and dishes** with a wash pump with soft start

Quality and long service life

- **Robust for heavy commercial use:** wash and final rinse arms as well as dosing pipes made of stainless steel
- **Remains cool and quiet outside** by double-walled construction with insulation of the door
- **Robust and hygienic** thanks to extended wash chamber with integrated rack guides
- **Protection of the machine components** by stainless steel rear panelling

Simple installation and service

- **Simple ordering, rapid delivery**
- **Plug&play:** complete connection kit for water, waste water and electricity included in scope of delivery
- **Fits everywhere:** drain pump makes installation independent of building discharge height (max. height 700 mm)
- **Simple service:** electronic interface and easy service access

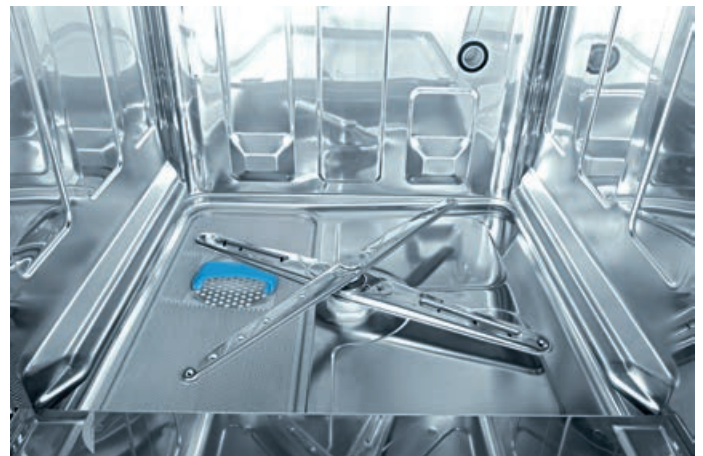

Wash chamber always clean thanks to comfortable automatic self-wash program

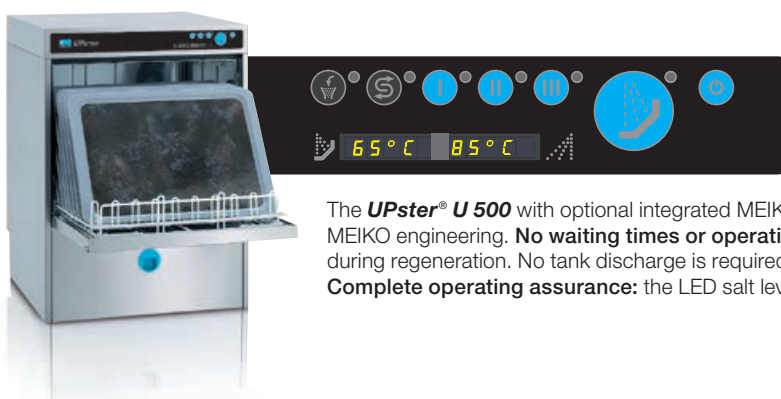

The *UPster® U 500* with optional integrated MEIKO *AktivClean* water softening is a highlight of MEIKO engineering. **No waiting times or operational interruptions:** washing can continue during regeneration. No tank discharge is required. It only has to be topped up with salt. **Complete operating assurance:** the LED salt level indicator ensures complete control.

UPster® U 500 / U 500 G

Everything for greater cleanliness and hygiene



The AktivPlus wash water filter system:

This means multiple filtered tank water and backup coarse screening for the pump – with easy handling of the system designed in. And that pays real dividends, producing sparkling cleanliness with minimal water consumption – just 2.6 litres of fresh water per wash cycle!



Consistently excellent wash results:

Economical 11 litre capacity of wash tank. Just the right amount, which is rapidly and with noticeable effect regenerated by the continuous fresh water final rinse.



A clean piece of work:

The deep-drawn, generously dimensioned washroom is easy to clean and clear. This is in part also due to the integrated rack guides and consistently rounded off corners.

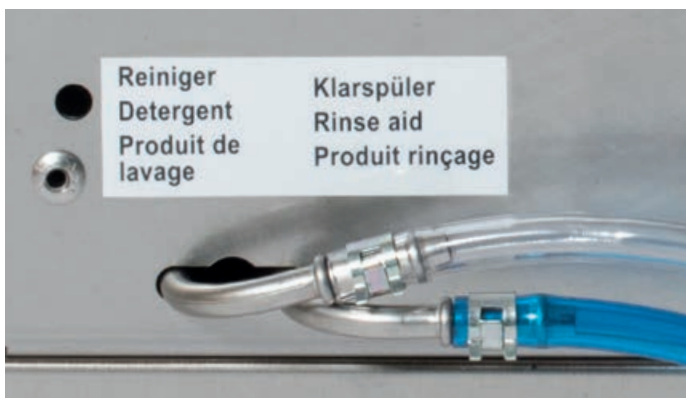

The prerequisites for a long service life:

Robust engineering and premium materials make the UPster® so reliable. Stainless steel, also for the dosing pipes, is therefore a must.



Quick, economical and reliable installation:

Thanks to the connection kit for water, waste water and electricity, every MEIKO UPster® is rapidly set up and even more quickly connected. The built-in drain pump can also connect to on-site drains outlets up to 700 mm in height.

MEIKO GiO MODULE – everything always brilliantly clean

Clean china and dry glasses are an absolute must. With the MEIKO GiO MODULE you will always shine because it ensures perfect washing results and a brilliant finish. Meaning that manual polishing was yesterday.

The MEIKO GiO MODULE is the reverse osmosis system for first class water treatment. With a purity of approx. 98 %, it produces almost completely desalinated water. The economic and environment-friendly way to perfectly shiny, clean and hygienically clean dishes.

The advantages of the MEIKO GiO MODULE at a glance:

- spotless wash and drying result
- valuable time savings:
 - no manual polishing up
 - faster loading and unloading
- fewer glass breakages
- no space wastage due to compact machine dimensions
- complete connection kit included in scope of delivery
- fully integrated into the dishwasher's control system

With the MEIKO "GiO MODULE" water treatment technology: No need to polish glasses ever again!

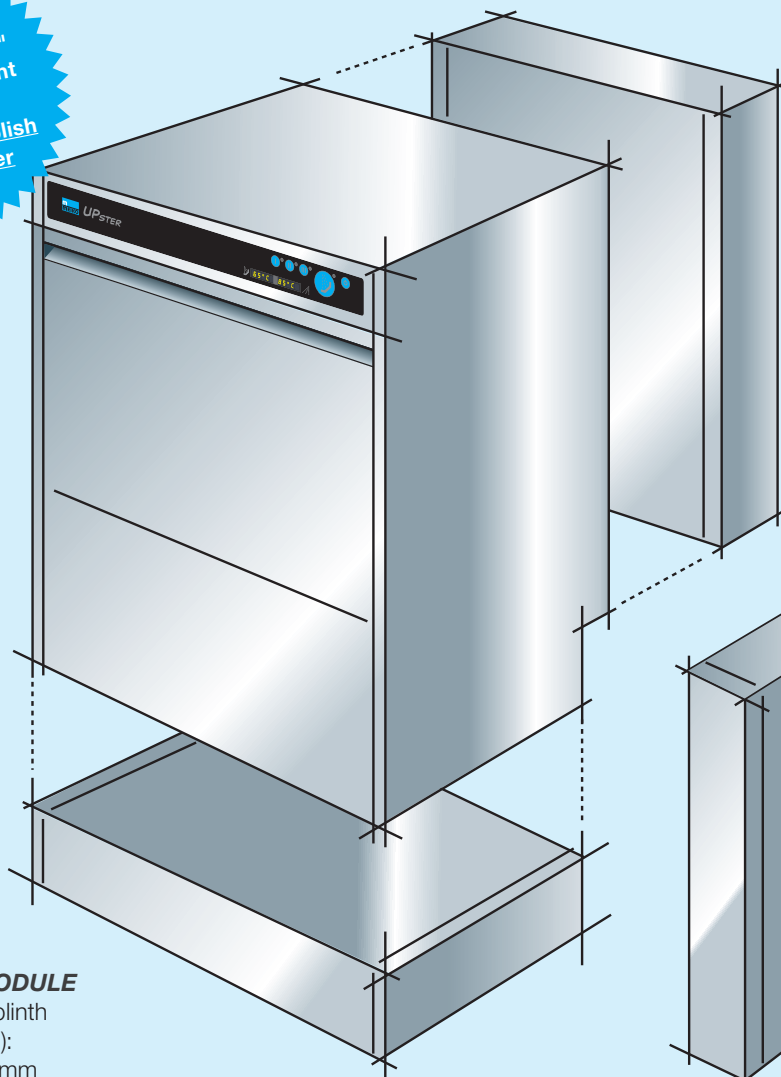

MEIKO GiO MODULE

on the rear panel of the machine
Dimensions (D):
 90 mm

MEIKO GiO MODULE

in the machine plinth
Dimensions (H):
 120 mm or 150 mm

MEIKO GiO MODULE

supplied separately
Dimensions (W x D x H)
 140 x 550 x 600 mm

UPster® H 500

Dishwashing is now almost a pleasure



The MEIKO *UPster*[®] H is designed for tableware and coffee cups, but also ideal as a high-performance dishwasher for glasses. With its sleek, easy-clean stainless steel surfaces and clearly designed, user-friendly operating panel, it offers impressive visual appeal from the outside. But things get even better on the inside: optimised wash and rinse system, perfected tank design and a unique filter system.



UPster® H 500

Ergonomic design and performance

Warewashing convenience in premium quality: the *UPster® H 500* offers powerful cleaning in an easy-to-use package. Even wide or high washware can be simply and conveniently pushed into the *UPster® H 500* sideways. Now simply press down the hood grip and off you go: the auto-

matic program start initiates the wash operation. Another plus: when you open the vapour escapes to the rear and not into the face of wash personnel. With some much operator comfort, the job almost becomes a pleasure!

UPster® H 500

Passing height

H 440 mm

Rack size

500 x 500 mm

Capacity

up to 40 racks/h

Comfort options:

- MEIKO *AirConcept*
- MEIKO *GiO MODULE* technology (fig.)
- Water change program



The *UPster® H 500* with optional integrated MEIKO *AktivClean* water softening is a highlight of MEIKO engineering. **No waiting times or operational interruptions:** washing can continue during regeneration. No tank discharge is required. It only has to be topped up with salt. **Complete operating assurance:** the LED salt level indicator ensures complete control.

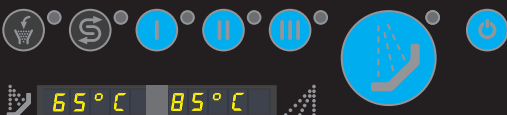

UPster® H 500

All the plus points at a glance

Comfort options:

- Improved indoor environment with MEIKO AirConcept
- Spotless brilliance with MEIKO GiO MODULE
- Water change program for uncomplicated reconditioning of wash water

The UPster® H 500 in figures

- More than enough space for big and small, for example euro trays, large dishes and tall glasses: passing height 440 mm
- A lot of space of glittering wash results: rack size 500 x 500 mm
- Economical water consumption: 2.6 l per wash cycle

Cleanliness and hygiene assurance

- Hygiene assurance without compromises thanks to digital temperature display for wash and final rinse temperatures, and permanent temperature control
- Excellent rinsing results due to excellent wash water filtration and optimum tank water regeneration with the AktivPlus wash water filter system
- Optimum drying: due to the inbuilt gradient in the wash and final rinse systems as well as the washing compartment ceiling, no drops fall on the cleaned washware
- Consistent, reliable cleaning results: Thanks to the pressure booster pump cleans the UPster® H 500 independently of the mains water pressure
- High operating reliability due to leak detection in base tray

Comfort and serviceability

- Uncomplicated operation with automatic program start: simply press down the hood grip to start the program
- Easy to understand blue operating concept eliminates risk of operator errors
- Always a clean wash chamber through the intuitive self-cleaning program and tank cover sieve for selective removal of dirt in the AktivPlus fine filter
- Protects glasses and dishes with a wash pump with soft start

Quality and durability

- Robust for heavy commercial use: wash and final rinse arms as well as dosing pipes made of stainless steel
- Remains cool and quiet outside by double-walled construction with insulation of the hood

Simple installation and service

- Simple ordering, rapid delivery
- Plug&play: complete connection kit for water, waste water and electricity included in scope of delivery
- Fits everywhere: drain pump makes installation independent of building discharge height (max. height 700 mm)
- Simple service: electronic interface and easy service access

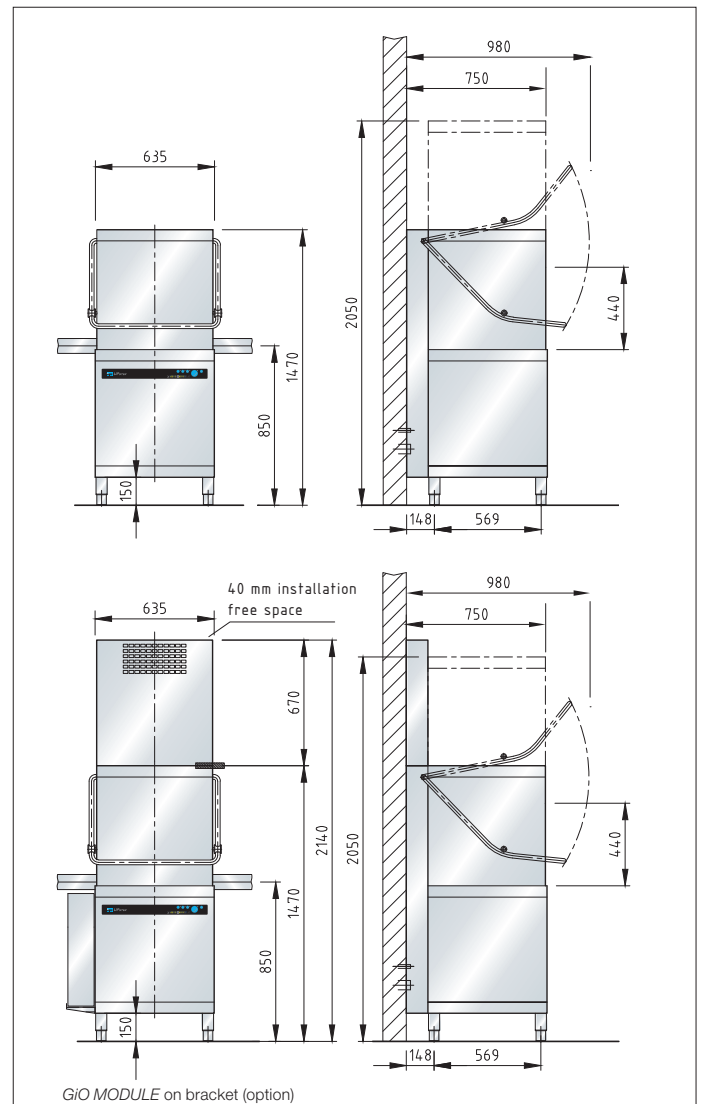

UPster® H 500

with MEIKO AirConcept



Bad air can take a hike

Steam and heat in the wash-up area are not only extremely uncomfortable and unpleasant for personnel, but also the most common cause of mould. The MEIKO *AirConcept* puts an end to this: it works hard to create an optimum hygiene, cleanliness and a better indoor climate. The MEIKO *AirConcept* noticeably improves the room climate and saves money. The steam discharge into the room is reduced by up to 80%. But it's more than just a comfort feature. What's more, it uses waste heat to heat up the rinse water, saving energy consumption by up to 18%. This is good for your employees and for the environment. Another highlight of the MEIKO *AirConcept* is the reliable self-cleaning function: Integrated cleaning nozzles keep the system hygienically clean after the end of the operation without consuming additional water. A really clean piece of work!

MEIKO AirConcept

All the plus points at a glance

- up to 80 % less steam discharge
- perceptibly improved interior climate
- greater hygiene assurance
- energy savings of up to 18 %
- accelerated self-drying of washware



Vapour extraction with self-cleaning at end of shift

Technical data		UPster® H 500
Self-cleaning feature (without additional water consumption)		Built-in cleaning nozzles
Vapour extraction (extended cycle time)	s	30
Reduction of heat emission into the room	kW	1.3
Exhaust air temperature (at feed water temperature of 12°C)	°C	approx. 25
Reduction of steam released into the room		80%
Reduction of connected load	kW	1.5

MEIKO GiO MODULE – everything brilliantly clean

Clean china and dry glasses are the visiting card of any catering operation. The MEIKO *GiO MODULE* creates that vital optimum first impression. The result is perfect washware without streaks and with spotless brilliance. Hand drying becomes a vague memory. The MEIKO *GiO MODULE* is the reverse osmosis system for first class water treatment. With a purity of approx. 98 %, it produces almost completely desalinated water. The economic and environment friendly way to perfectly shiny, clean and hygienically clean washware.

The advantages of the MEIKO GiO MODULE at a glance:

- spotless wash and drying result
- valuable time savings:
 - no manual polishing up
 - faster loading and unloading
- fewer glass breakages
- no space wastage due to compact machine dimensions
- complete connection kit included in scope of delivery
- fully integrated into the dishwasher control system

With the MEIKO "GiO MODULE" water treatment technology:
No need to polish glasses ever again!

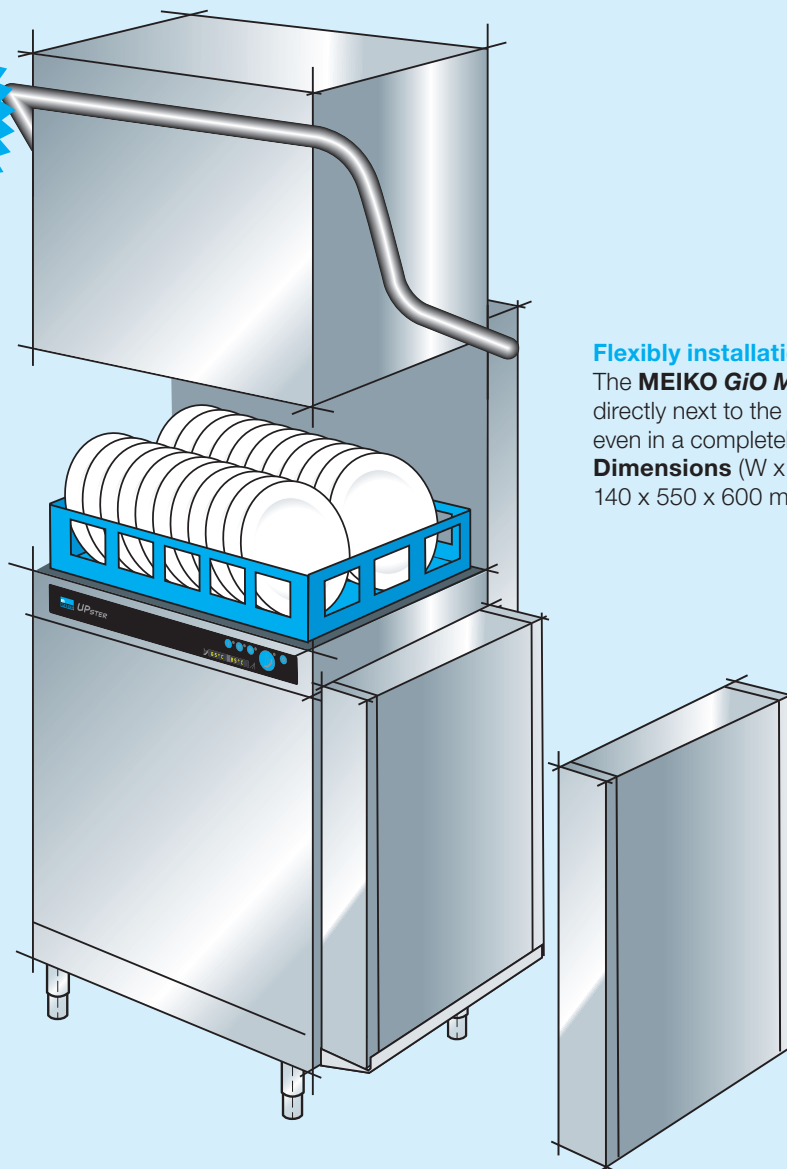

Flexibly installation:

The **MEIKO GiO MODULE** can be installed directly next to the machine, in its proximity or even in a completely different room.

Dimensions (W x D x H)
140 x 550 x 600 mm

UPster® H 500

Detailed engineering

The comfort functions



Elegantly simple: the wash chamber

Cleverly designed, easily removable strainer screens cover the wash tank below.

NEW! Blue operating concept, further optimised wash arm.



Clean: the AktivPlus wash water filter system

Fine filter system which works in tandem with the strainer screens to provide optimum wash water through multiple filtration. That means the tank water stays clean longer, ensuring the best and most hygienic cleaning results.

Quick and safe: the installation

Easy-to-use connection kit for water, waste water and power. The built-in drain pump allows waste discharge up to a height of 700 mm.



The height of convenience: 440 mm usable passing height

Easily accommodates euro trays, large items dishware, tall glasses etc.



Ergonomic handling thanks to all-around hood grip

Simply press down the hood grip to start the program.

Safety first

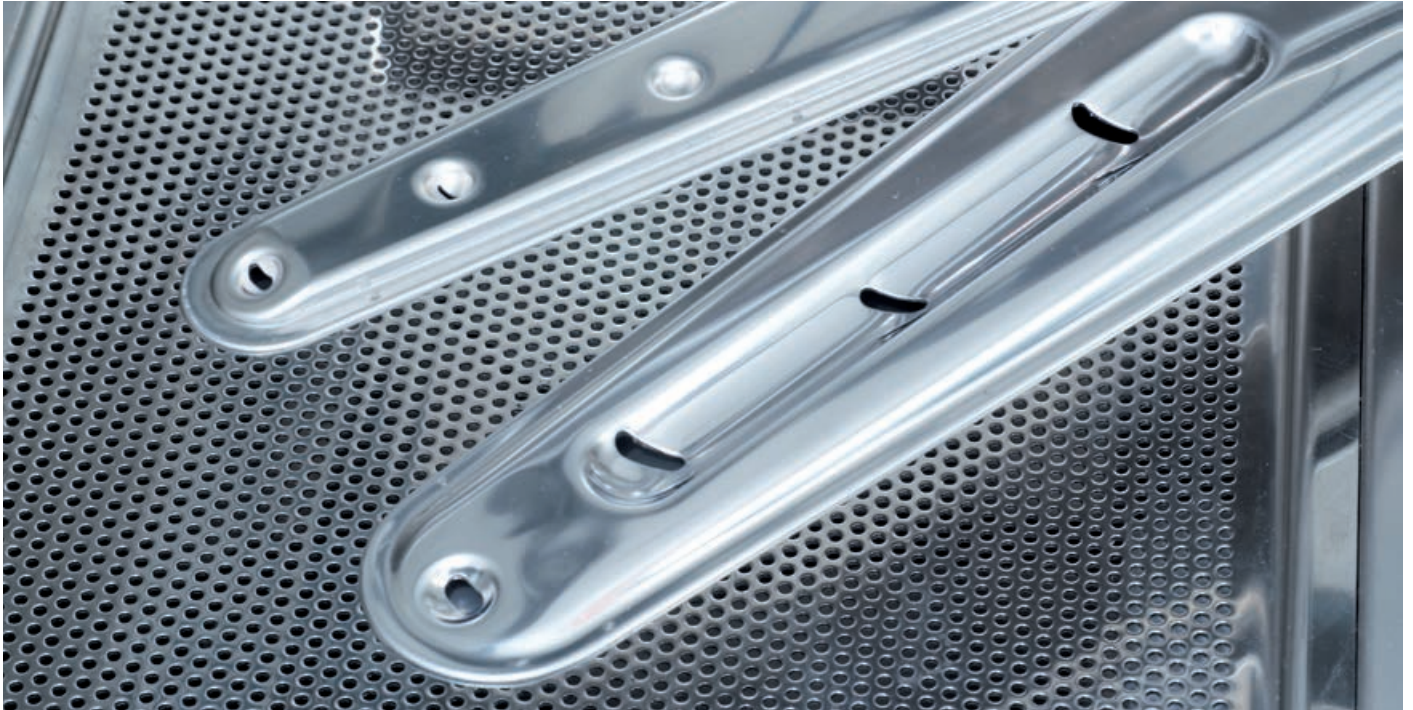

Only robust engineering and premium materials guarantee top-quality cleaning results
Therefore only stainless steel was good enough for our wash and rinse arms.

The MEIKO *AktivPlus* wash water filter system

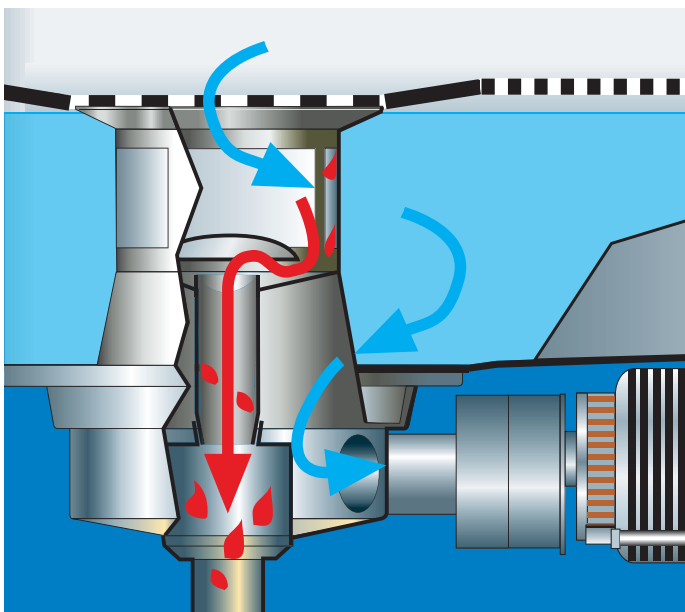

Outstanding cleaning results
thanks to multiple filtration of tank water.

The water change program (option)

Replace the water in the tank at the touch of a button, and continue rinsing immediately with fresh new water. This simple, fully automatic process – ensures hygienic rinsing and optimum results.

Leakage detection system in base drip tray



Outstanding cleaning results thanks to automatic leakage control, optimum protection of all built-in components.

UPster®

Customised planning, installation and loading

Whether in a straight line or around a corner: The ideal design of the MEIKO UPster® H 500 creates almost unlimited installation options. For the most effective wash organization, MEIKO offers a comprehensive product range with numerous other table variants. From a simple roller conveyor

table to a complete dishwashing station with integrated glasswasher – there are (almost) no limits to the possibilities. Talk to us! The experts from MEIKO are happy to design an individual solution for you.



Combined and ready for all requirements

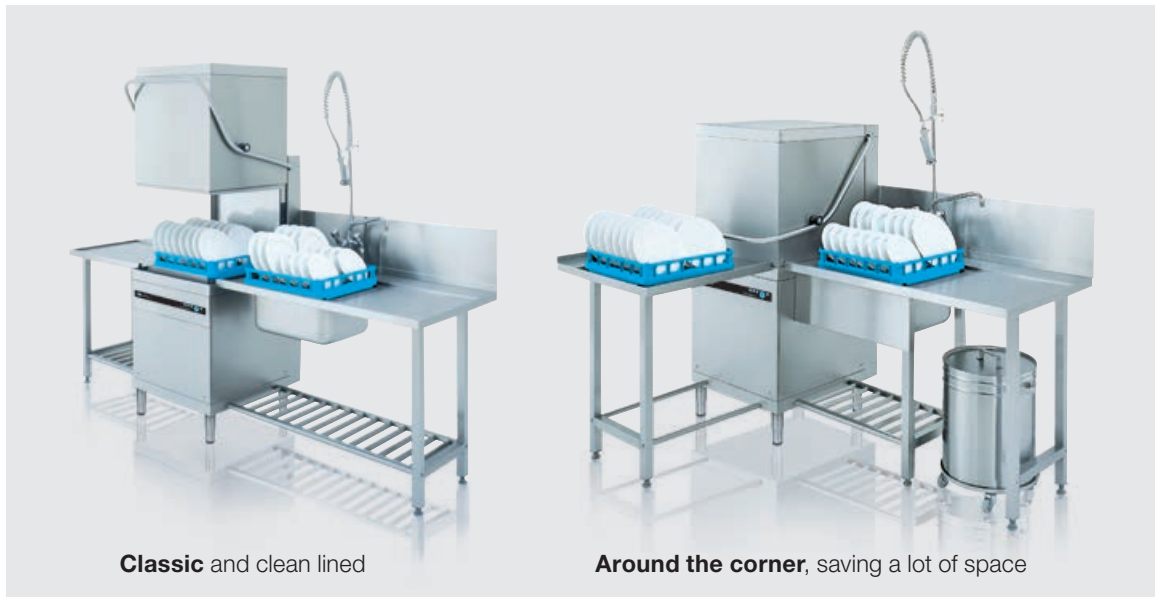

MEIKO Service

Everything for a long machine service



A key factor in the durability of the *UPster*[®] products is the outstanding MEIKO Service. As a manufacturer of premium dishwashing technology, MEIKO sets high standards in terms of quality, reliability and quality assurance. These standards also apply to our nationwide after-sales service network of authorised and qualified service technicians. As *UPster*[®] customer you benefit from the short response times and high quality of MEIKO Service: A network of 1,800 service partners is available 365 days a year.

As *UPster*[®] customer you benefit from these MEIKO service benefits:

- competent service personnel
- comprehensive service network worldwide with high availability
- always in the vicinity – short response times
- professional and brand-appropriate repairs in proven MEIKO quality
- efficient and prompt repair
- thorough and correct maintenance
- rapid and smooth support

Technical briefing

Initial installation

Training and authorisation

Support on site

Spare parts supply and repairs

Short response time



UPster® U / UPster® H

Clean solutions in all sizes



Technical data		UPster® U 400		UPster® U 500 G		UPster® U 500		UPster® H 500
		230 V	400 V	230 V	400 V	230 V	400 V	400 V
Tank heating	kW	2.0		2.0		2.0		2.0
Boiler heating	kW	2.0	3.0	2.0	6.0	2.0	6.0	7.5*
Pump output	kW	0.55		0.55		0.55		0.75
Total connected load	kW	2.8	3.8	3.0	7.0	3.0	7.0	10.6
Final rinse	l/rack	2.2		2.6		2.6		2.6
Tank capacity	l	11.0		11.0		11.0		22.0
Entry height/passing height	mm	300		315		420		440
Rack dimensions	mm	400 x 400		500 x 500		500 x 500		500 x 500
Program cycle times**	s	120/180/240		90/120/240		90/120/240		90/150/210
Theoretical								
rack capacities	up to racks/h	30/20/15		40/20/15		40/30/15		40/24/17
plate capacities	up to plates/h			720		720		720
glass capacities	up to glasses/h	750		1,440		1,440		1,440

* Option of increased heat output available (at no extra cost).

** If the machine is connected to a cold water supply and/or if baskets are inserted in quick succession, the duration of the wash cycles may be increased to achieve hygienic final rinse temperatures.

Please note that the design of ventilation systems for wash-up areas must comply with VDI 2052 regulations.

UPster® U 400, UPster® U 500 G, UPster® U 500

Electrical installation

Electrical connection: three phase 3/N/PE, 400 V, 50 Hz; or with alternating current on site 1/N/PE, 230 V, 50 Hz.

Boiler and tank heating electrically interlocked so that both cannot be operated at the same time. Circuitry complies with the requirements of the Association of German Electrical Engineers (VDE).

Water installation

The machines can be connected directly to the fresh water supply without the use of intermediate safety valves.

Minimum flow pressure 0.6 bar (2.5 bar with UPster® U 400 with optional pressure booster pump), maximum pressure 5 bar.

The installation requirements of EN 1717 must be observed.

Drain DN 22 (fitted inside the machine as siphon).

Connecting hoses can be positioned below the machine or to the left or right.

(1 bar = 100 kPa)

UPster® H 500

Electrical installation

Electrical connection: three phase 3/N/PE, 400 V, 50 Hz.

Water installation

The machines can be connected directly to the fresh water supply without the use of intermediate safety valves.

Min. flow pressure 0.6 bar, max. pressure 5 bar.

The installation requirements of EN 1717 must be observed.

Drain DN 22. Connecting hoses can be positioned below the machine or to the left or right.

UPster® U 500 G, UPster® U 500, UPster® H 500

GiO MODULE

Cold water connection (max. 35 °C), min. flow pressure 1 bar, max. pressure 5 bar. Conductivity of raw water <1000 µS/cm. Total water hardness max. 28 °dH.

Connection kit: 1 m reinforced hose, stop valve, 10 µm filter with activated carbon, pressure regulator, 2 m reinforced hose to machine. Drain kit: concentrate drain hose approx. 2 m, drain piping incl. backflow preventer. Free discharge type AA as per EN 1717.

Permeate line and electrical cable between machine and separate GiO MODULE approx. 3 m. When using the GiO MODULE a backflow preventer is required for the mains water supply to ensure DIN-compliant operation as per EN 1717 (optional).

(1 bar = 100 kPa) (1 °dH approx. 0.18 mmol/l CaCO₃)



Meets the hygiene requirements of DIN SPEC 10534.

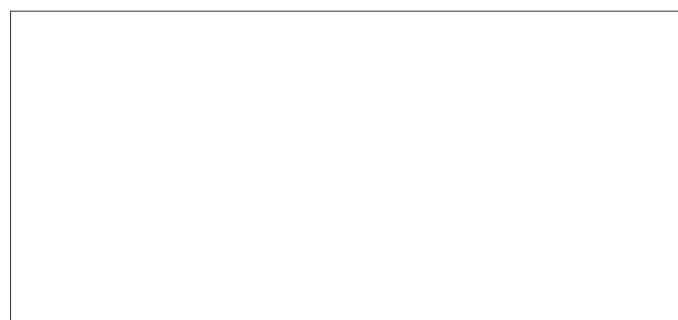

121.063.01.09.18/EN/DD/2500

We reserve the right to amend specifications as part of our product improvement process